

# ROCKY MOUNTAIN

H A R D W A R E

## Entry Mortise Lock - Grip to Grip

- 1 Escutcheon
- 2 Turn Piece
- 3 Mortise Lock
- 4 Scalp
- 5 Mortise Lock Strike
- 6 Mortise Lock Dust Box
- 7 Mortise Cylinder
- 8 Cylinder Swing Cover
- 9 Thumb Latch
- 10 Grip

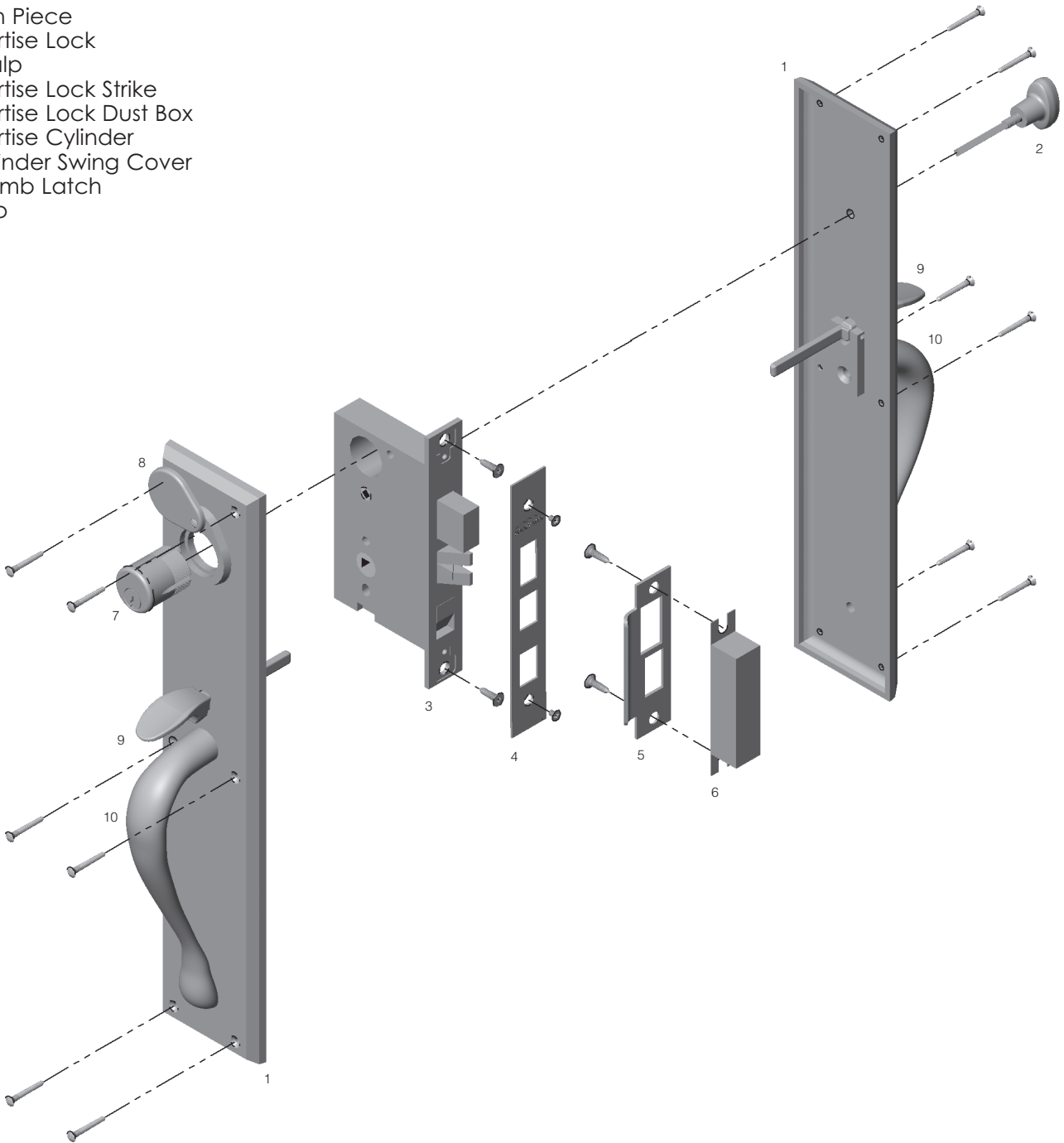

Note: Thumb latch (#9) and Turn Piece (#2) to be cut in the field.



## Mortise Lock Installation Instructions

### 1. Mark the Door

The standard location of the mortise lock is determined by placing the center of the lever or knob at 36" above the finished floor. **However, this may be adjusted for special applications with larger escutcheons where the exterior trim needs to be cheated 36" above finished floor. To ensure placement, layout the escutcheon on the door before boring to confirm it is placed at the appropriate height for the size of the escutcheon/door.**

### 2. Compare Lock, Hardware Trim and Door Conditions

Verify that the stile width is adequate to accept the mortise lock and hardware trim. Make sure the hardware trim does not interfere with the door stop or the astragal and does not overlap the door panel or glass.

### 3. Mortising Lock Cavity

Refer to the Door Preparatory Specifications sheets for the specific dimensions of the cavity. Mortise the cavity. Please note that on doors thicker than 3.5" the placement of the mortise lock may need to be offset to the keyed side in order to accommodate a maximum mortise cylinder length of 2.25.

### 4. Mortising Lock Front

Refer to the Door Preparatory Specifications sheets for the specific dimensions of the lock front mortise. Mortise the edge of the door for lock front.

### 5. Cut Relief Pockets

Cut the relief pockets in the lock cavity at the latch bolt location. This will allow the latch bolt to retract without interference from the lock cavity.

### 6. Mark Face of Door

Use the Door Preparatory Specifications sheets to determine the appropriate locations of the holes on the face of the door for the lock and hardware trim. Please note the correct backset.

### 7. Drill Holes

Verify all dimensions and locations from Step 6, then drill the holes.

### 8. Adjust Bevel and Install Lock

To adjust the bevel, loosen the screws on the top and bottom of the lock body behind the lock front. Do not remove the screws. The lock front can rotate so that the bevel on the lock front matches the bevel on the edge of the door. Once the bevels match, tighten the screws so that the lock front is held in place. Install the lock in the door. If the bevel is set properly, the body of the lock will be square to the door and centered in the cavity. Every mortise lock must be centered in the cavity and the bevel properly adjusted to ensure a correct installation. Failure to center the lock or adjust the bevel will lead to an incorrect installation.

### 9. Grip by Lever/ Knob Trim Grip by Grip Trim Only

Install the spindle spring into the back of the lever or knob and the spindle into the hub of the mortise lock. If the set is a grip by grip, there is no spindle to install. Cut the thumb piece (or pieces, if it is a Grip by Grip) to length so that it will fully engage the mechanism in the bottom of the lock but will not interfere with the inside wall of the cavity.



## Mortise Lock Installation Instructions (continued)

### 10. Knob by Knob or Lever by Lever Trim Only

Insert the spindle springs into the back of the backs of the levers or knobs and the spindle into the hub of the mortise lock.

### 11. Install Cylinder

**Installing the cylinder must be done before attaching exterior trim onto the door.** Rotate the swing cover so the cylinder can be placed through the lock trim. Insert the key half way into the cylinder and carefully thread the cylinder through the lock trim, into the lock. Do not screw the lock trim to the door before threading the cylinder into the lock, as it will interfere with the threading process. Tighten and loosen the cylinder into the lock so that the Rocky Mtn. logo is right side up, and the cylinder face does not interfere with the swing cover. Tighten the cylinder set screw so that it holds the cylinder firmly in place. Do not over tighten the cylinder or the set screws.

### 12. Attach Exterior Lock Trim

Once the cylinder has been secured, the exterior lock trim can be installed. Make sure the lock trim is plumb and properly aligned in all directions before drilling the pilot holes for the escutcheon screws. (The use of a vix bit or other self-centering drill bit is highly recommended for drilling the pilot holes.) Thread the escutcheon screws through the lock trim into the pilot holes and tighten to secure the lock trim to the door. The use of cordless or other power drills to drive in the screws is not recommended as they increase the chance of stripping the screws or scratching the lock trim.

### 13. Attach Interior Lock Trim

Cut the shank on the turn piece so that it reaches half way through the lock. Follow the same procedure to attach the interior as with the exterior trim.

### 14. Install Scalp

Attach the finished scalp to the lock front.

### 15. Strike Installation

Use the Door Preparatory Specifications sheets to determine the proper location of the strike. Mortise the jamb or astragal to the proper depth to accept the strike and dust box. Install strike and dust box.

### General Notes

**1.** Make sure all door conditions are compatible with the lock mechanism and lock trim before drilling or mortising the door. If there are any issues with the lock or trim, please contact the Distributor that provided the hardware immediately.

**2. DO NOT OPEN THE MORTISE LOCK BODY FOR ANY REASON.** All warranties will be voided if the lock body, is opened and a replacement lock will have to be purchased at full price.

**3.** Hardware should be removed from door before painting or finishing of the door. Allow finish to fully cure before reinstalling hardware. Refer to paint manufacturer for instructions and curing times.



## Operation of Mortise Lock Sets

### Lock Operation Grip by Lever/ Knob

When the set is unlocked, the interior lever or knob and the exterior thumb piece will retract the latch bolt. The exterior thumb piece can be locked by pushing in on the top of the toggle on the face of the lock that can be seen on the edge of the door. The interior lever or knob will still be able to retract the latch bolt. The dead bolt can be thrown by either the turn piece on the interior side of the door or the key from the exterior side of the door. The toggle on the face of the lock at the edge of the door will automatically be pushed in at the top of the toggle when the dead bolt is thrown by either the turn piece or the key, locking the exterior thumb piece. Rotating the interior lever or knob will retract both the dead bolt and the latch bolt simultaneously. Rotating the key will retract the dead bolt first, then by continuing to rotate the key, the latch bolt will be retracted allowing the door to open. The retraction of the dead bolt will not reverse the toggle position, so the exterior thumb piece will still be locked. The exterior thumb piece can be unlocked by pushing in on the bottom of the toggle on the lock face at the edge of the door.

### Lock Operation Lever by Lever or Knob by Knob

When the set is unlocked, the interior lever or knob and the exterior lever or knob will retract the latch bolt. The exterior lever or knob can be locked by pushing in on the top of the toggle on the face of the lock that can be seen on the edge of the door. The interior lever or knob will still be able to retract the latch bolt. The dead bolt can be thrown by either the turn piece on the interior side of the door or the key from the exterior side of the door. The toggle on the face of the lock at the edge of the door will automatically be pushed in at the top of the toggle when the dead bolt is thrown by either the turn piece or the key, locking the exterior lever or knob. Rotating the interior lever or knob will retract both the dead bolt and the latch bolt simultaneously. Rotating the key will retract the dead bolt first, then by continuing to rotate the key, the latch bolt will be retracted allowing the door to open. The retraction of the dead bolt will not reverse the toggle position, so the exterior lever or knob will still be locked. The exterior lever or knob can be unlocked by pushing in on the bottom of the toggle on the lock face at the edge of the door.

### Lock Operation Grip by Grip

When the set is unlocked, the interior thumb piece and the exterior thumb piece will retract the latch bolt. The exterior thumb piece can be locked by pushing in on the top of the toggle on the face of the lock that can be seen on the edge of the door. The interior thumb piece will still be able to retract the latch bolt. The dead bolt can be thrown by either the turn piece on the interior side of the door or the key from the exterior side of the door. Rotating the turn piece from the interior side of the door will retract the dead bolt and then the interior thumb piece will retract the latch bolt. Rotating the key will retract the dead bolt first, then by continuing to rotate the key, the latch bolt will be retracted allowing the door to open. The retraction of the dead bolt will not reverse the toggle position, so the exterior thumb piece will still be locked. The exterior thumb piece can be unlocked by pushing in on the bottom of the toggle on the lock face at the edge of the door.

# ROCKY MOUNTAIN

H A R D W A R E

## EDGE COLLECTION - DOOR PREPARATORY SPECIFICATIONS

### Entry Grip to Grip Mortise Lock - Interior

Not Applicable to Element, or Bluetooth Options

Notes:

1. Standard location of mortise lock is determined by placing the lever or knob 36" above finish floor. However, this may be adjusted for special applications.
2. This bore specification is applicable for 2 1/2" or 2 3/4" backset mortise locks.
3. 1 3/4" minimum door thickness.

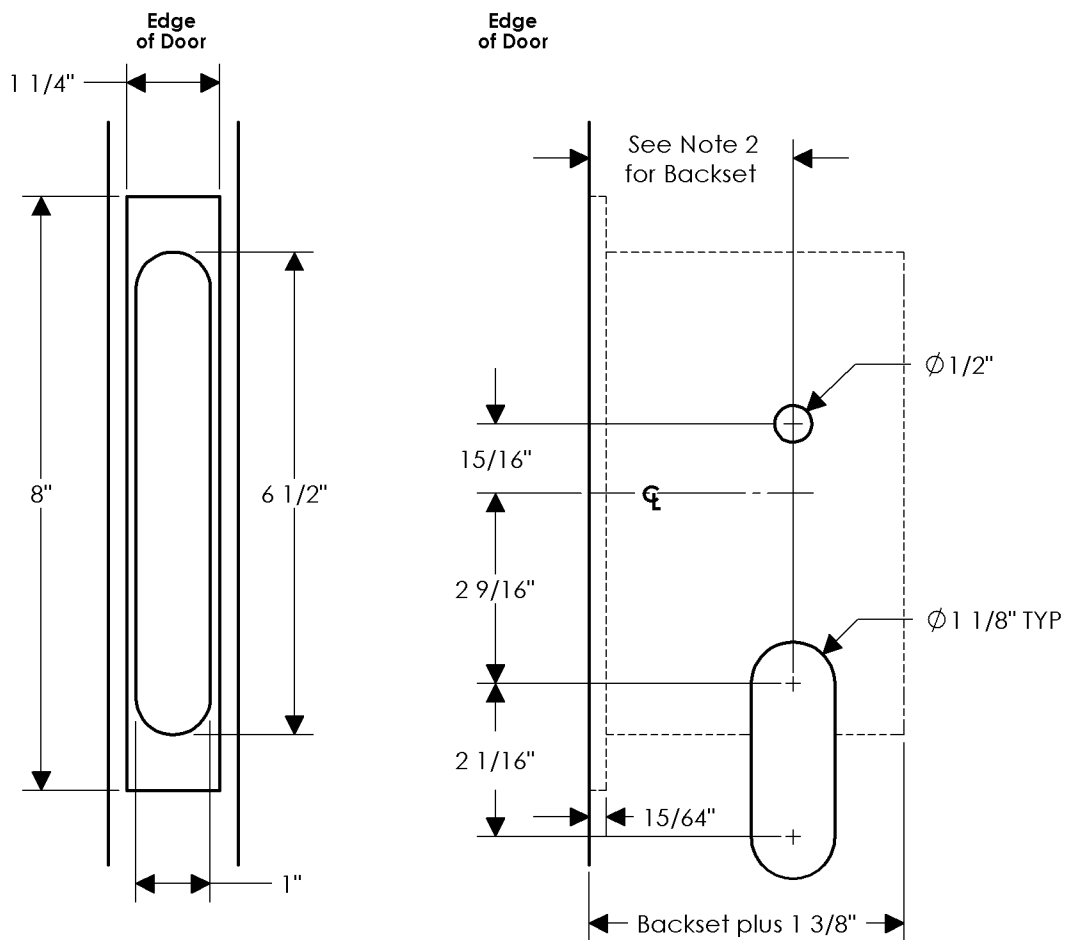

# ROCKY MOUNTAIN

H A R D W A R E

## EDGE COLLECTION - DOOR PREPARATORY SPECIFICATIONS

### Entry Grip to Grip Mortise Lock - Exterior

Not Applicable to Element, or Bluetooth Options

Notes:

1. Standard location of mortise lock is determined by placing the lever or knob 36" above finish floor. However, this may be adjusted for special applications.
2. This bore specification is applicable for 2 1/2" or 2 3/4" backset mortise locks.
3. 1 3/4" minimum door thickness.

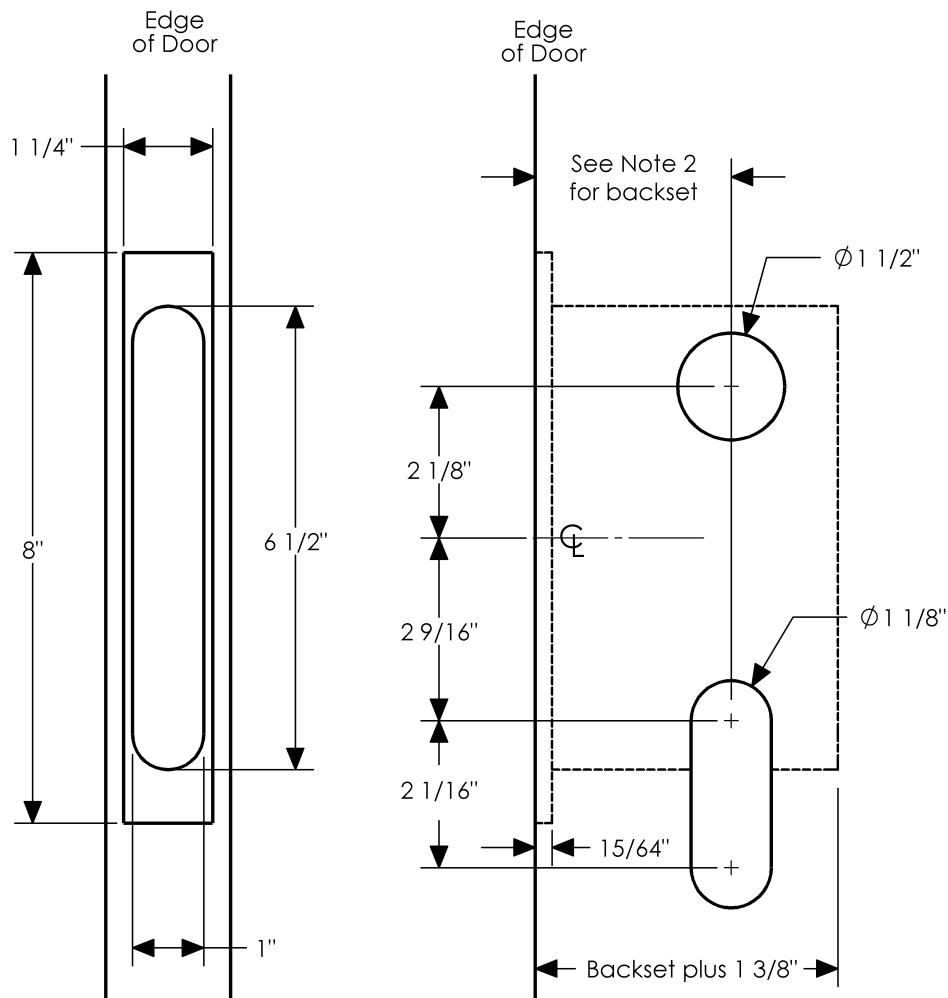

# ROCKY MOUNTAIN

H A R D W A R E

## EDGE COLLECTION - DOOR PREPARATORY SPECIFICATIONS

### Strike - Mortise Lock

Notes:

1. This dimension is 1/2 of door thickness, eg., 1 3/4" divided by 2 = 7/8". This dimension will have to be adjusted for different door thicknesses and unusual jamb or door conditions.

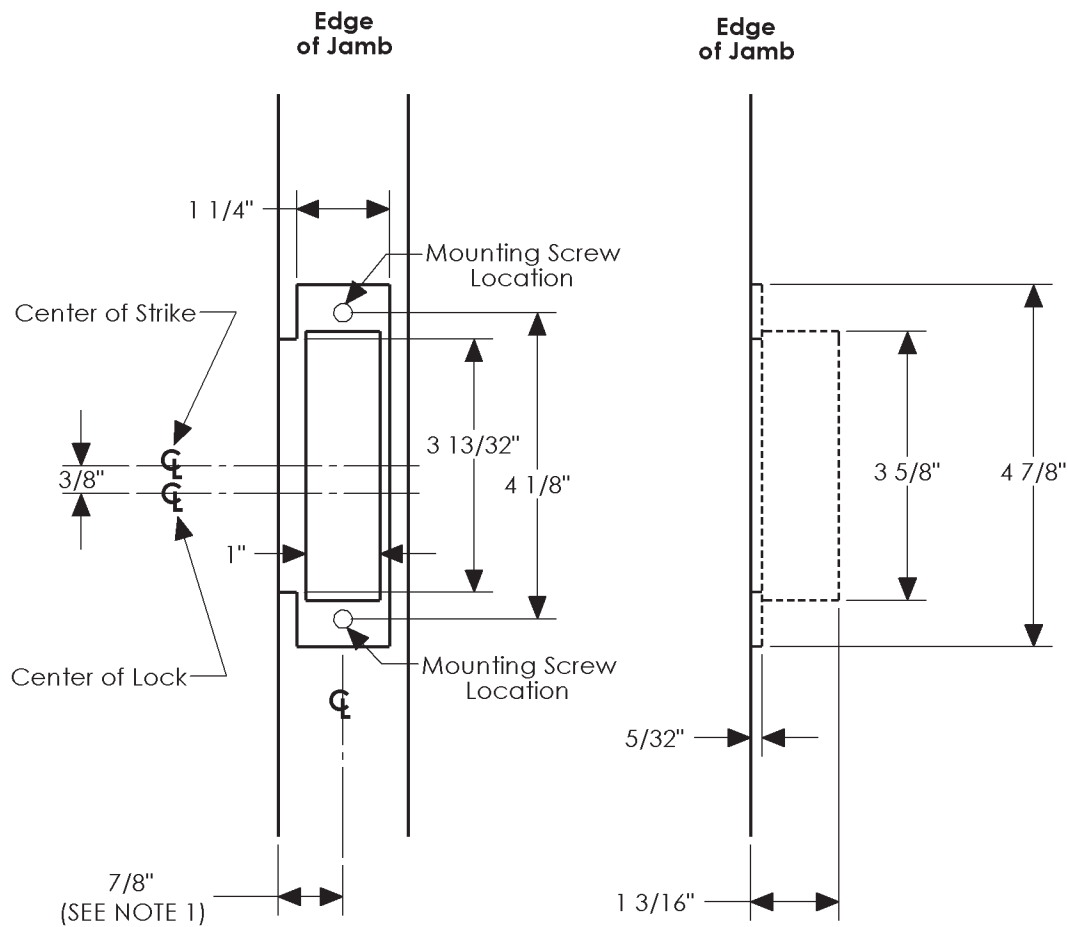

Scan For Video Instructions